

閥類型符號 SYMBOL

CRG-※

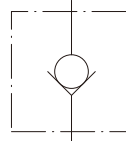

CRG-※

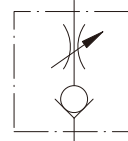

CRG-※-M

規格說明 SPECIFICATION :

型式 MODLE		最高使用壓力 MAX. OPERATED PRESSURE (kgf/cm ²)	開啓壓力 CREAKING PRESSURE kgf/cm ²	流量 RATED FLOW l/min	重量 WEIGHT kg	
CRG-03-※-10	CRG-03-※-20	250	05 : 0.35	40	3.3	1.9
CRG-06-※-10	CRG-06-※-20		50 : 3.5	125	4.2	3.2
CRG-10-※-10	CRG-10-※-20		75 : 5	250	7.7	6

型號說明 HOW TO ORDER :

CRG - 03 - 05 - 10 - SE

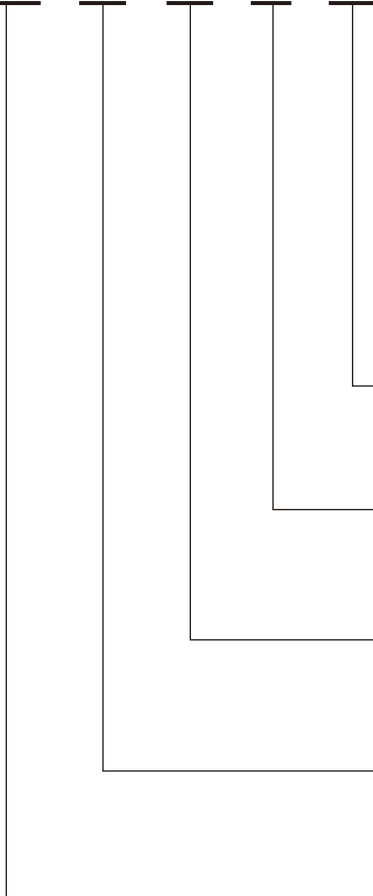

附屬品 ATTACHMENT :

型式 MODLE	安裝螺絲 SOC HOL CAP SCREW
CRG-03-10	M10 X 50L.....4pcs
CRG-06-10	M16 X 60L.....4pcs
CRG-10-10	M20 X 75L.....4pcs
CRG-03-20	M10 X 45L.....4pcs
CRG-06-20	M10 X 50L.....4pcs
CRG-10-20	M10 X 55L.....6pcs

外部引導PT-1/4" EXTERNAL PILOT PT-1/4"

設計編號 DESIGN NUMBER
10 : 非ISO規格 NO-ISO STANDARD
20 : 標準ISO規格 ISO STANDARD

開啓壓力 CREAKING PRESSURE
05 : 0.35 kgf / cm² 50 : 3.5 kgf / cm²
75 : 5 kgf / cm²

閥規格 VALVE SIZE
03 : 3 / 8" 06 : 3 / 4" 10 : 1 - 1 / 4"

系列編號 SERIES NUMBER

安裝尺寸

INSTALLATION DIMENSIONS

CRG-03-10

通用底板尺寸
 APPLICATIVE
 SUB-PLATE DIMENSIONS
MC - 01 - 1
 (詳見 F-f1-09 Page F-f1-09)

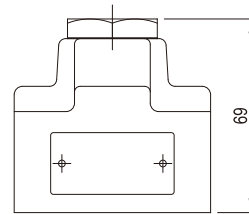
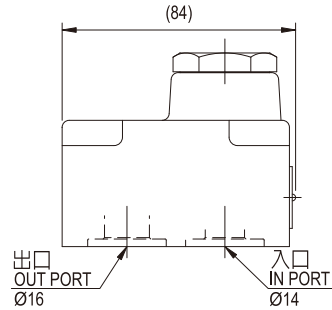
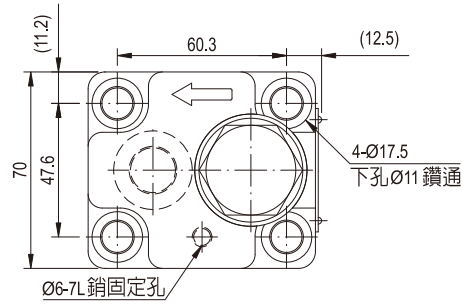

CRG-06-10

通用底板尺寸
 APPLICATIVE
 SUB-PLATE DIMENSIONS
MC - 01 - 2
 (詳見 F-f1-09 Page F-f1-09)

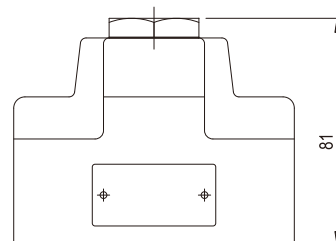
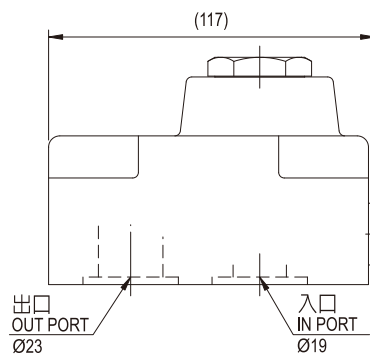
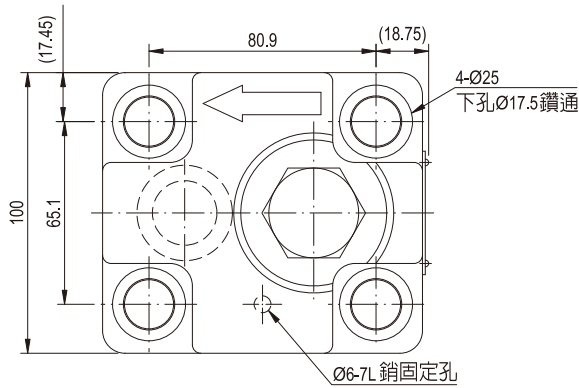

單位UNIT : mm

安裝尺寸

INSTALLATION DIMENSIONS

CRG-10-10

通用底板尺寸
 APPLICATIVE
 SUB-PLATE DIMENSIONS
MC - 01 - 3
 (詳見 F-f1-09 Page F-f1-09)

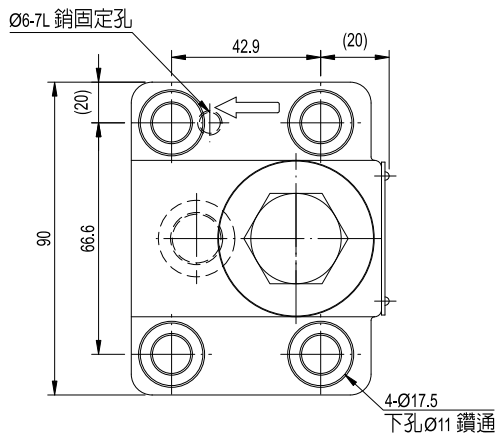
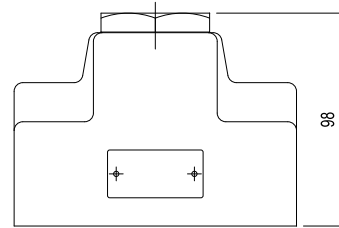
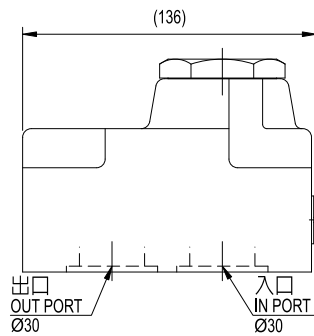
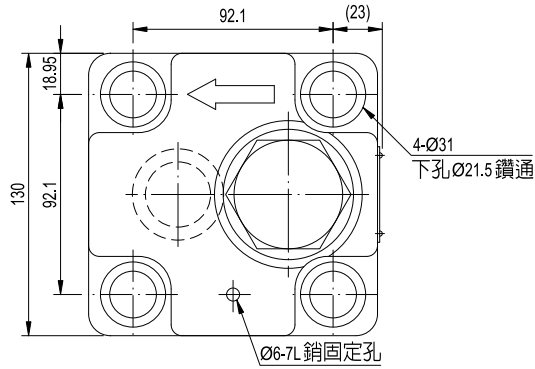

CRG-03-20

通用底板尺寸
 APPLICATIVE
 SUB-PLATE DIMENSIONS
MC - 01 - 4
 (詳見 F-f1-09 Page F-f1-09)

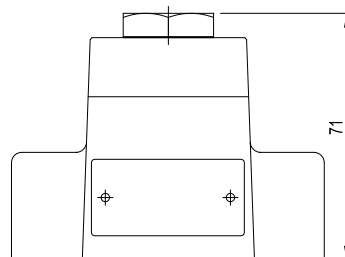
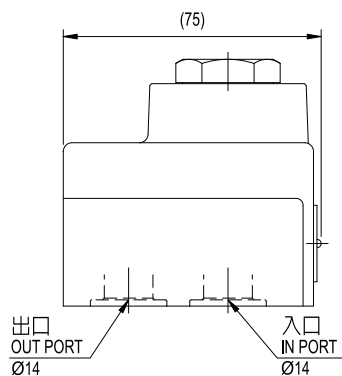

單位UNIT : mm

安裝尺寸 INSTALLATION DIMENSIONS

CRG-06-20

通用底板尺寸
 APPLICATIVE
 SUB-PLATE DIMENSIONS
MC - 01 - 5
 (詳見 F-f1-09 Page F-f1-09)

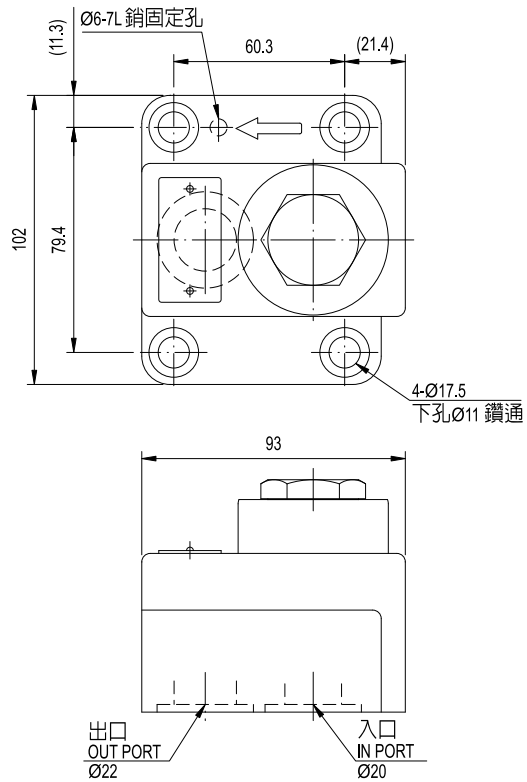

CRG-10-20

通用底板尺寸
 APPLICATIVE
 SUB-PLATE DIMENSIONS
MC - 01 - 6
 (詳見 F-f1-09 Page F-f1-09)

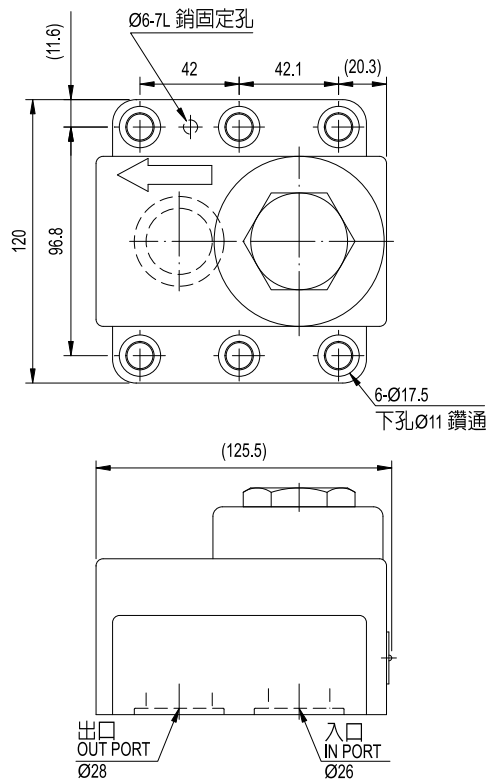

單位UNIT : mm

安裝尺寸

INSTALLATION DIMENSIONS

CRG-03-10-M

通用底板尺寸
 APPLICATIVE
 SUB-PLATE DIMENSIONS
MC - 01 - 1
 (詳見 F-f1-09 Page F-f1-09)

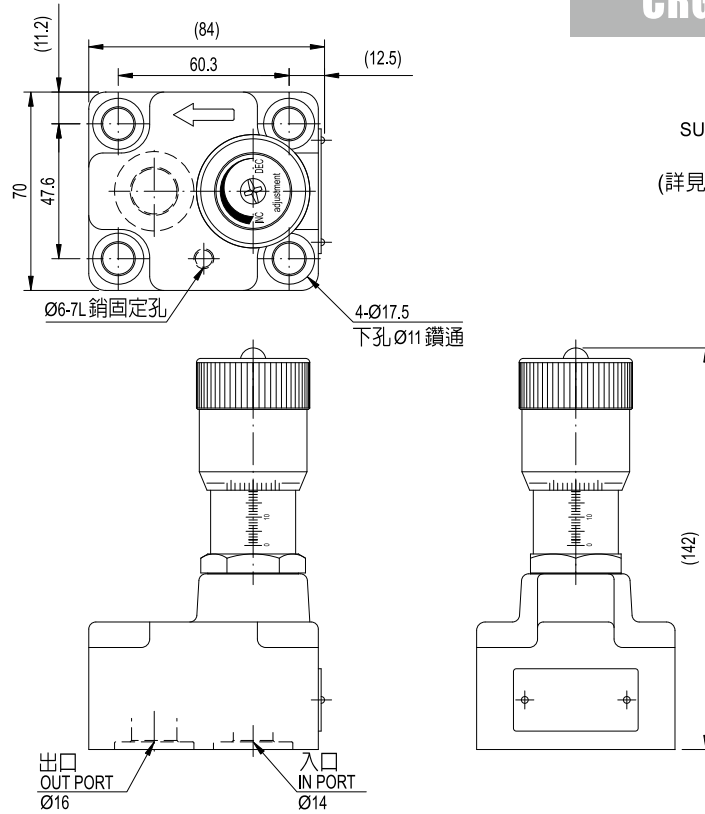

CRG-06-10-M

通用底板尺寸
 APPLICATIVE
 SUB-PLATE DIMENSIONS
MC - 01 - 2
 (詳見 F-f1-09 Page F-f1-09)

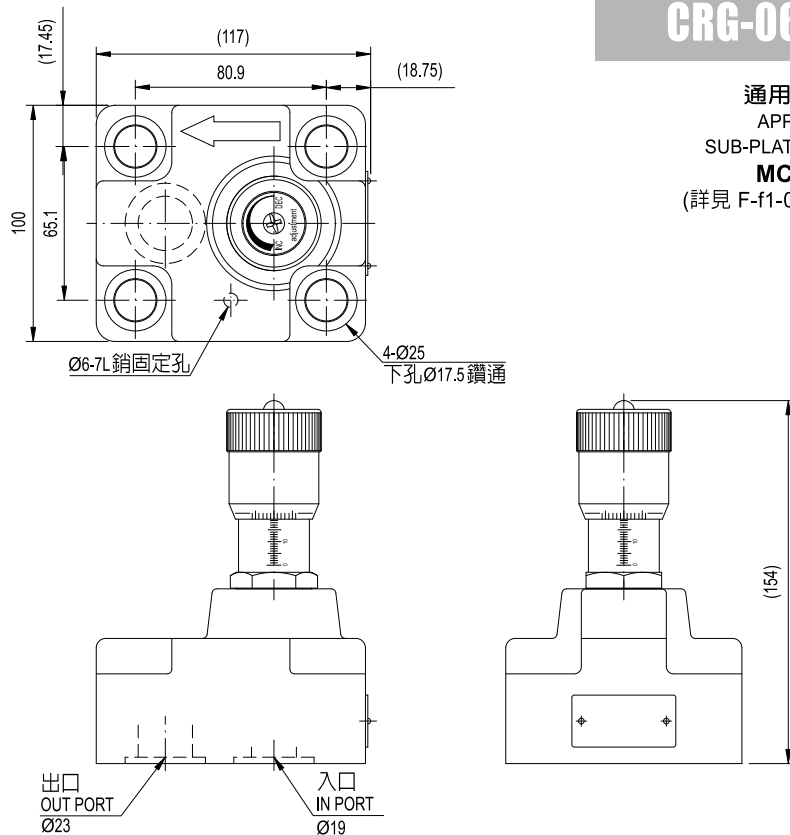

單位UNIT : mm

安裝尺寸

INSTALLATION DIMENSIONS

CRG-10-10-M

通用底板尺寸
 APPLICATIVE
 SUB-PLATE DIMENSIONS
MC - 01 - 3
 (詳見 F-f1-09 Page F-f1-09)

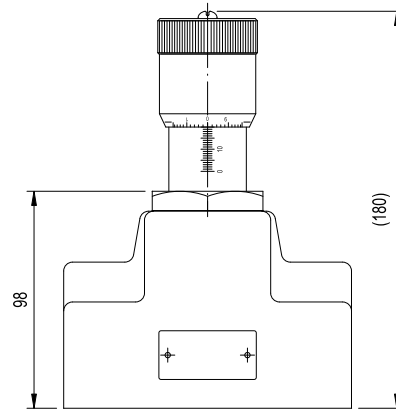
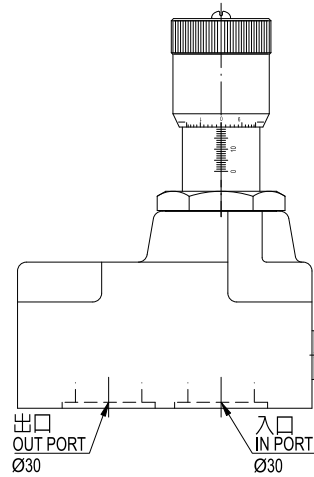
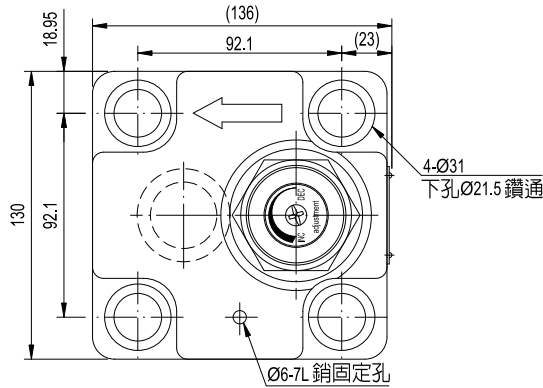

測試條件

PERFORMANCE CURVES:

測試油黏度 TEST FLUID VISCOSITY : 35 cSt

測試油溫度 TEST TEMPERATURE : 50°C

● CRG-03

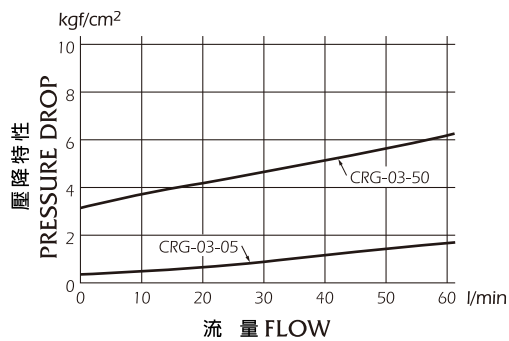

● CRG-06

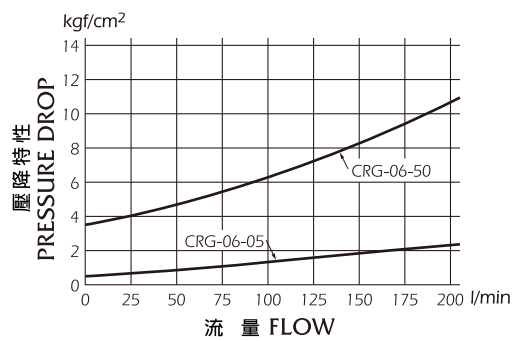

● CRG-10

